

# 100-150 Watts

## RDQ Series



- 110 VDC Input for Rail Applications
- Up to 92% Efficiency
- Quarter and Half Brick Packages
- -40 °C to +100 °C Operating Temperature
- Baseplate-cooled
- Remote On/Off & Remote Sense
- 3 Year Warranty

### Specification

#### Input

- Input Voltage Range • 66-160 VDC
- Input Current • See table
- Idle Current • 50 mA
- Input Filter • Pi network (see note 3)
- Undervoltage Lockout • Turn on 62.0 V, turn off 56.0 V
- Input Surge • 180 VDC for 100 ms

#### Output

- Output Voltage Trim • ±10%, see application notes
- Initial Set Accuracy • ±1.5% max
- Line Regulation • ±0.2% max measured from high line to low line
- Load Regulation • ±0.2% max measured from 0-100% load
- Start Up Time • 60 ms typical
- Transient Response • 5% max deviation, recovery to within 1% in 200 µs, 25% step load change
- Ripple & Noise • 5 V models: 100 mV pk-pk  
12 V models: 150 mV max pk-pk  
24 V models: 240 mV max pk-pk  
20 MHz bandwidth (see note 1)
- Overvoltage Protection • 115-140%
- Short Circuit Protection • Continuous
- Current Limit • 110-180% nominal output
- Thermal Shutdown • Case temperature >105 °C typical
- Temperature Coefficient • ±0.03%/°C
- Remote On/Off • Referenced to -Vin, Module on = open circuit, Module off ≤0.8 VDC
- Remote Sense • Compensates up to 10% of Vout nominal, total of output trim and remote sense

#### General

- Efficiency • See tables
- Isolation Voltage • 2250 VDC Input to Output  
2250 VDC Input to Case  
1500 VDC Output to Case
- Isolation Resistance • 10<sup>7</sup>Ω
- Isolation Capacitance • 1000 pF typical
- Switching Frequency • 200 kHz typical
- Power Density • RDQ100: 60 W/in<sup>3</sup>, RDQ150: 54 W/in<sup>3</sup>
- MTBF • 380 kHrs typical to MIL-HDBK-217F at 25 °C, GB

#### Environmental

- Operating Base Plate Temperature • -40 °C to +100 °C, see derating curve
- Storage Temperature • -55 °C to +105 °C
- Operating Humidity • Up to 95% non-condensing
- Cooling • Baseplate-cooled, see derating curve
- Cooling Test • EN60068-2-1, -40 °C for 2 hours
- Dry Heat • EN60068-2-2, 70 °C for 6 hours
- Damp Heat • EN60068-2-30, 25 °C to 55 °C, 90-100% humidity, 2 cycles of 24 hours
- Vibration • EN61373, 2 Hz to 150 Hz, 5.72m/s<sup>2</sup> on X axis, 2.55m/s<sup>2</sup> on Y axis, 3.96m/s<sup>2</sup> on Z axis
- Shock • EN61373, 50m/s<sup>2</sup> half sine 30ms, 3 positive and 3 negative on X axis, 30m/s<sup>2</sup> half sine 30ms, 3 positive and 3 negative on Y and Z axes,
- Supply Variation • EN50155, 0.7 to 1.4 Vn
- Supply Interruption • EN50155, 100% for 10 ms
- Supply Change-Over • EN50155, 0.6 Vn for 100 ms
- Insulation Test • EN50155, 500 VDC
- Voltage Withstand • EN50155, 2250 VDC
- Supply Over-Voltage • EN50155, 1.4 Vn for 0.1 s

#### EMC & Safety

- General • Complies with EN50121-3-2, Railway Applications - Electromagnetic Compatibility for Rolling Stock Apparatus
- Emissions • EN55011, 99 dBµV (0.15-0.5 MHz), 93 dBµV (0.5-30 MHz) conducted, class A radiated, EN55022 Level B conducted with external filter, see Application Notes.
- ESD Immunity • EN61000-4-2 Air ±8kV, contact ±6kV, indirect ±6kV, Perf Criteria A
- Radiated Immunity • EN61000-4-3 80-1000 MHz at 20 V/m, 1400-2100 MHz at 10V/m, 2100-2500 MHz at 5 V/m, Perf Criteria A
- EFT/Burst • EN61000-4-4 level 3, Perf Criteria A
- Surge • EN61000-4-5 level 2, Perf Criteria A\*
- Conducted Immunity • EN61000-4-6 10 Vrms, Perf Criteria A
- Safety Approval • UL60950-1 (basic insulation)

#### Notes

\* External TVS is required on the input. See Application Notes.

## Models & Ratings

Input Voltage	Output Voltage	Output Current	Input Current		Efficiency	Maximum Capacitive Load	Model Number <sup>(2)</sup>
			No Load	Full Load			
66-160 V	5.0 V	20.0 A	30 mA	1010 mA	90.0%	10000 $\mu$ F	RDQ100110S05
	12.0 V	8.40 A	40 mA	993 mA	90.0%	8800 $\mu$ F	RDQ100110S12
	24.0 V	4.20 A	60 mA	1030 mA	91.0%	1500 $\mu$ F	RDQ100110S24

### Notes

- Output Ripple and Noise measured with 10  $\mu$ F tantalum and 1  $\mu$ F ceramic capacitor across output.
- Add suffix 'N' to the model number to receive the unit with negative logic Remote On/Off.

- An external 120  $\mu$ F electrolytic input capacitor is recommended to reduce input ripple voltage.

## Mechanical Details

### RDQ100

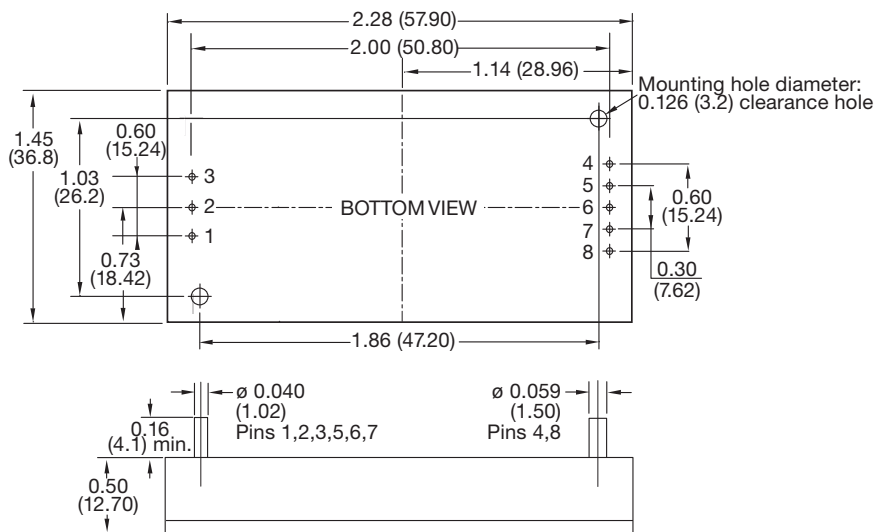

PIN CONNECTIONS	
Pin	Function
1	+Vin
2	Remote On/Off
3	-Vin
4	-Vout
5	-Sense
6	Trim
7	+Sense
8	+Vout

### Notes

- Dimensions are in inches (mm)
- Tolerances: X.XX =  $\pm 0.02$  (X.X =  $\pm 0.5$ )  
X.XXX =  $\pm 0.01$  (X.XX =  $\pm 0.25$ )
- Weight: 0.13616 lbs (61.5 g) approx

## Thermal Resistance Information (Derating Curve)

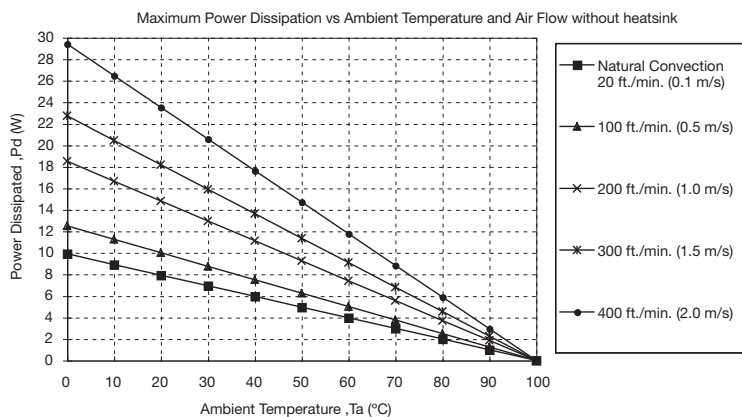

Air Flow Rate	Typical $R_{ca}$
Natural Convection 20 ft. / min (0.1 ms)	10.1 $^{\circ}$ C/W
100 ft./min (0.5 ms)	8.0 $^{\circ}$ C/W
200 ft./min (1.0 ms)	5.4 $^{\circ}$ C/W
300 ft./min (1.5 ms)	4.4 $^{\circ}$ C/W
400 ft./min (2.0 ms)	3.4 $^{\circ}$ C/W

$R_{ca}$  = Thermal resistance case to ambient

## Models & Ratings

Input Voltage	Output Voltage	Output Current	Input Current		Efficiency	Maximum Capacitive Load	Model Number <sup>(2)</sup>
			No Load	Full Load			
66-160 V	5.0 V	30.0 A	40 mA	1474 mA	92.5%	10000 $\mu$ F	RDQ150110S05
	12.0 V	12.5 A	40 mA	1474 mA	92.5%	5600 $\mu$ F	RDQ150110S12
	24.0 V	6.50 A	60 mA	1541 mA	91.0%	2200 $\mu$ F	RDQ150110S24

### Notes

- Output Ripple and Noise measured with 10  $\mu$ F tantalum and 1  $\mu$ F ceramic capacitor across output.
- Add suffix 'N' to the model number to receive the unit with negative logic Remote On/Off.
- An external 220  $\mu$ F electrolytic input capacitor is recommended to reduce input ripple voltage.

## Mechanical Details

### RDQ150

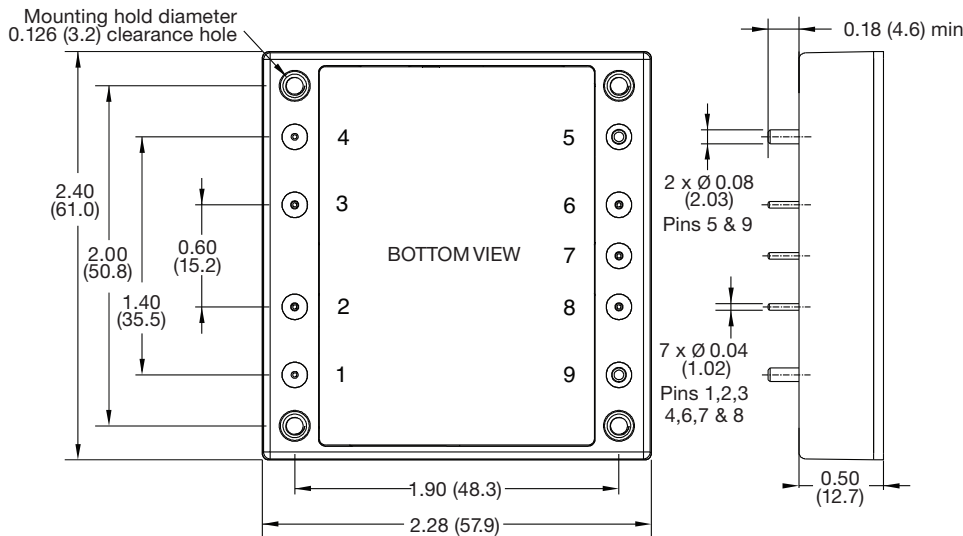

PIN CONNECTIONS	
Pin	Function
1	+Vin
2	Remote On/Off
3	Case
4	-Vin
5	-Vout
6	-Sense
7	Trim
8	+Sense
9	+Vout

### Notes

- Dimensions are in inches (mm)
- Tolerances: X.XX =  $\pm 0.02$  (X.X =  $\pm 0.5$ )  
X.XXX =  $\pm 0.01$  (X.XX =  $\pm 0.25$ )
- Weight: 0.216 lbs (90 g) approx

## Thermal Resistance Information (Derating Curve)

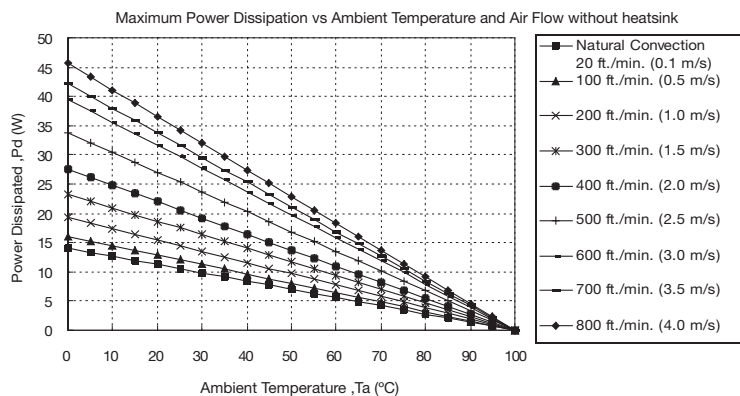

Air Flow Rate	Typical R <sub>ca</sub>
Natural Convection 20 ft./min (0.1 m/s)	7.12 °C/W
100 ft./min (0.5 m/s)	6.21 °C/W
200 ft./min (1.0 m/s)	5.17 °C/W
300 ft./min (1.5 m/s)	4.29 °C/W
400 ft./min (2.0 m/s)	3.64 °C/W
500 ft./min (2.5 m/s)	2.96 °C/W
600 ft./min (3.0 m/s)	2.53 °C/W
700 ft./min (3.5 m/s)	2.37 °C/W
800 ft./min (4.0 m/s)	2.19 °C/W

R<sub>ca</sub> = Thermal resistance case to ambient

## Application Notes

### Suggested EMC Components

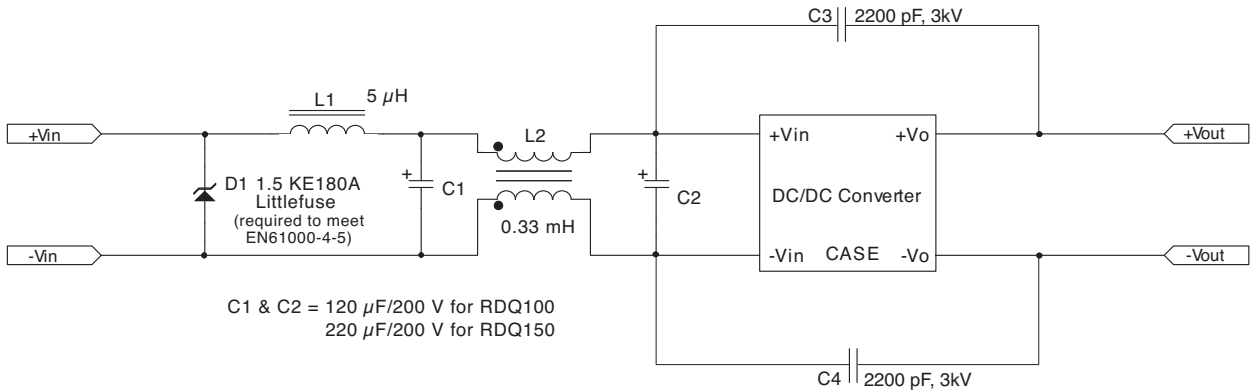

## Application Notes

### Output Voltage Trim

#### Voltage trim up

Connect trim resistor Rtrim between Trim pin and -Sense pin.

#### Voltage trim down

Connect trim resistor Rtrim between Trim pin and +Sense pin.

$$R \text{ trim up} = \left( \frac{R1 \left( Vr - Vf \left( \frac{R2}{R2 + R3} \right) \right)}{Vdes - Vnom} \right) - \frac{R2 \times R3}{R2 + R3} \text{ (k}\Omega\text{)}$$

$$R \text{ trim down} = \frac{R1 \times (Vdes - Vr)}{Vnom - Vdes} - R2 \text{ (k}\Omega\text{)}$$

Where: R trim up/down is the external resistor in kΩ. Vnom is the nominal output voltage. Vdes is the desired output voltage. R1, R2, R3 and Vr are internal to the unit and are defined in the table below.

Output Voltage (V)	R1 (k )	R2 (k )	R3 (k )	Vr (V)	Vf (V)
5.0 V	2.32	3.3	0	2.5	0.0
12.0 V	9.10	51.0	5.1	2.5	0.46
24.0 V	20.0	100.0	7.5	2.5	0.46

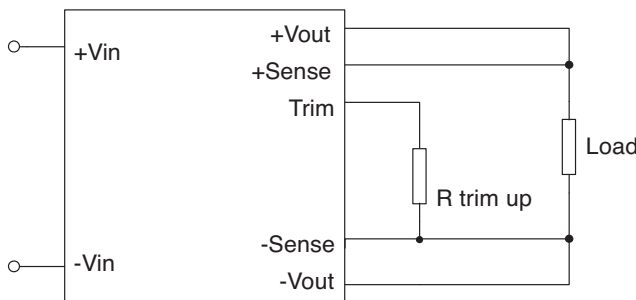

Voltage Trim-up Setup

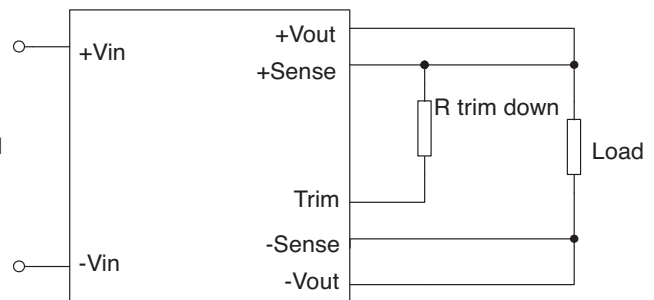

Voltage Trim-down Setup